



# The Mystery of Memory: No “Life”, No Memory

Mukhopadhyay AK\*

AIIMS, New Delhi, India

## Abstract

The issue of memory is mysterious in terms of its acquisition, storage, recall and retrieval. Memory is inextricably intertwined with the phenomenon of subtlety of “life”. So, is the process of learning. This paper builds up a testable theory proposing where there is no life, there is no memory. In this sense, the memory in a lifeless Artificial Device (AI) is a misnomer. So is the term, “Machine Learning”. The mystery calls for investigations on what is “life”, and its link with the memory.

**Keywords:** Correct definition of Memory; Memory in AI; Information-states; Spiritual implications of Memory; Requirement of brain in Memory; Immersive Neuroscience

## Introduction

We begin with a confession that we are confused whether the memory is composed of only data and signal, or of other information states? How such memory of different information states is formed, stored, recalled and retrieved? What is the mechanism of natural or conscious forgetting? How and why do we forget certain issues but remember others? Why are we not yet precisely sure of different mechanisms of memory loss in different kinds of dementia, although knowing of loss of cortical and hippocampal neurons and their connectivity? Why is there no memory acquisition, storage, recall and retrieval in a life-less brain, or in a brain-dead patient, in spite of the availability of the whole neural and glial network? How is there complete memory loss during passage through death? Why is having a memory of a previous birth an exceptional event? Why are we silent on the issue of absence of memory, whatsoever, in any of the devices of artificial intelligence? Without systematic purging of memory, and acquisition of new memory is it possible to explain evolution of species and transformation of the being! All such unanswered questions make the memory mysterious, and call for more investigations on memory!

## OPEN ACCESS

### \*Correspondence:

Ashok Kumar Mukhopadhyay, All India Institute of Medical Sciences (AIIMS), and North DMC Medical College & HRH, Delhi, India, Tel: 91 1179600585, +91 9999400332;

Received Date: 26 Sep 2023

Accepted Date: 13 Oct 2023

Published Date: 18 Oct 2023

### Citation:

Mukhopadhyay AK. The Mystery of Memory: No “Life”, No Memory. World J Psychiatry Ment Health Res. 2023; 6(1): 1035.

**Copyright** © 2023 Mukhopadhyay AK. This is an open access article distributed under the Creative Commons Attribution License, which permits unrestricted use, distribution, and reproduction in any medium, provided the original work is properly cited.

## Incompleteness of the Definition of Memory in the School of Engineering

Does an electrical switch, which lights a bulb or moves a fan, have memory? The process follows an instruction by manual movement of the switch to conduct electricity from the source to the output. Obviously, this is not a memory! Similarly, a computer or its equivalent, electronically communicates a set of instructions coded sequentially in form of signals, thus already programmed, following manual movement of the letters on the keyboard (Figure 1). From the data stored in the hardware, it matches who is the person working on the computer from the password already fed. Is it an explicit memory? Or, is it simple data handling according to a set algorithm?

Are input of signal and acquisition of data synonymous? Unlikely! Or this is an object/subject error! Do the output of data and the retrieval of data mean the same? Or, is it a passivity-activity issue! Are storing of data and memory storage synonymous? According to many, these seem to be overlapping events! How can we label the stored data in an artificial device as memory in absence of perception, and digging into the meaning of the data as information! Can “data” be stored only in the form of a coded signal? Does signal represent all kinds of information states? According to Electronics and Communication Engineering (ECE), however, a computer has explicit memory, but no working memory, and implicit memory. These kinds of ambiguous statements become obvious when we do not know what the memory is!

## Recovering the Meaning of Memory in its Definition

The author is of the view that memorization is an active, and not a passive process. In a mechanical device the input of data and its encoding and storage is done by a program represented by an algorithm of a set of sequential commands. The retrieval of the fed data is merely an output by another set of algorithms! It is a passive process. It could be anything but memory! Further,

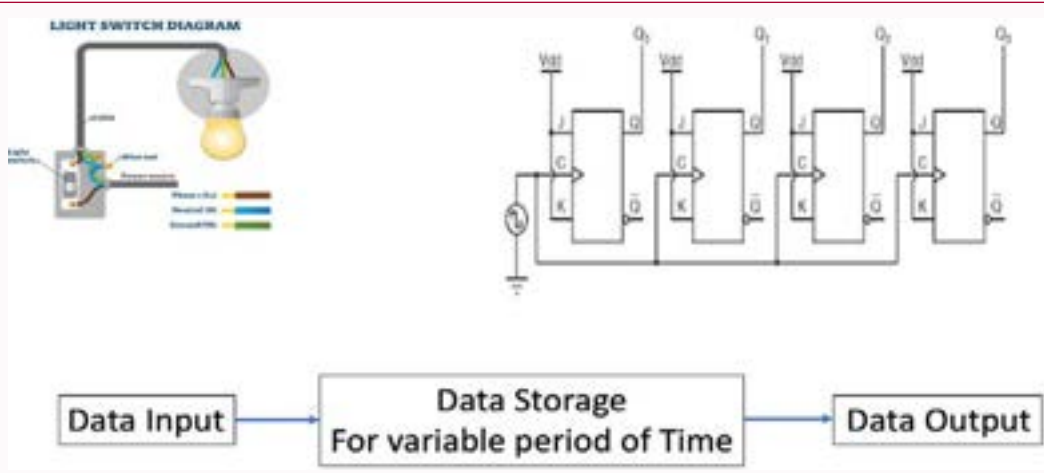

**Figure 1:** Input of data into a device, its storage within, and the output as and when required could be labelled at best as a schedule of program for an action, in both of the cases whether conducted by electricity or electrons, mechanized as switch board and wiring or by sequentially placed integrated circuits. The so-called intelligence as observed in the program resides within the programmer's head, and without doubt is reflected in the program. Nonetheless, the device knows nothing, has no memory, and possesses zero learning capacity.

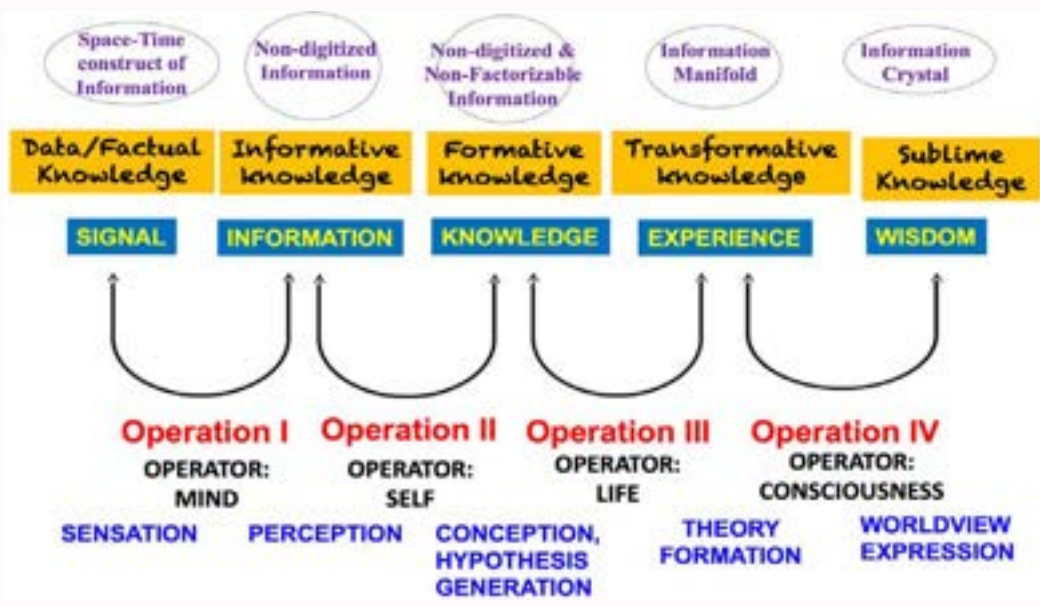

**Figure 2:** Start your observation with the central horizontal axis of the figure. On the left, it begins with signal, followed by, Information, Knowledge, Experience, and at the extreme right ends with Wisdom. In terms of knowledge, these milestones have been represented by data/factual knowledge, informative knowledge, formative knowledge, transformative knowledge and sublime knowledge. On the top most line the figure describes the same milestones in the language of science of information, starting with space-time construct of information, non-digitized information, non-digitized and non-factorizable information, information manifold and information crystal. Neurologically, signals lead to sensation, information to perception, knowledge to building up of concept and generation of hypothesis, experience to theory formation, and the wisdom to Worldview expression. Over the five landmarks/milestones there are four operations expressed numerically from the left to right, Operations I, II, III and IV operated by the non-observable but influential operators. Operator I has been popularly known as what is called Mind, Operator II has been mystically labelled as Self, Operator III, in the language of science, is called Life, and the Operator IV has been known in scientific and spiritual terms as Consciousness.

data is not the only information state! There is information-as-such (which is non-digitized), there is knowledge (symmetry of several information ensembled, non-digitizable and non-factorizable), experience (information manifolds) and wisdom (information crystal) too (Figure 2). It is obvious, that the process of memory formation cannot run in the absence of cognition, without the system's awareness, and without any sort of perception. Recall and retrieval of the desired data segment from the pool of stored information-states is passively possible in a mechanical system in absence of awareness by a preformed chain of commands, which is often mistaken for a conscious recall! Further, the memory is essential for any kind of

learning. In the absence of memory formation, there may be an automated signal-driven exercise, called training. However, there is little trace of the element of learning, or education in the process! In this sense, the term "machine learning" is a misnomer!

**Signal/Data is not the only Information State**

The author in his previous works [1-3] has already narrated in detail various possible information states for developing a science of information. The states are summarized in Figure 2.

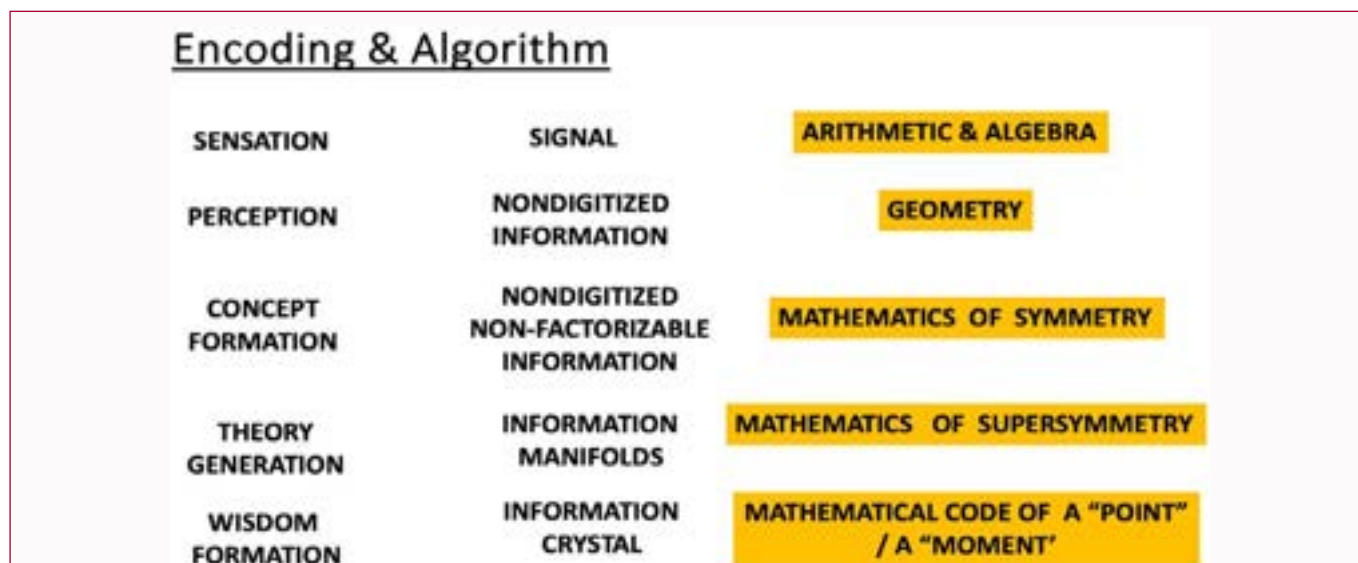

**Figure 3:** Signal could be encoded and expressed in the terms of arithmetic/algebra. It is suggested that for encoding perception and subsequent algorithms, one needs geometry. For mechanization of a concept, there is requirement of a mathematics of symmetry, and for the theory-making one requires a mathematics of supersymmetry. For playing with the wisdom in a mechanized device, the herculean task is to encode, and devise an algorithm with the mathematics of singularity or of a "point".

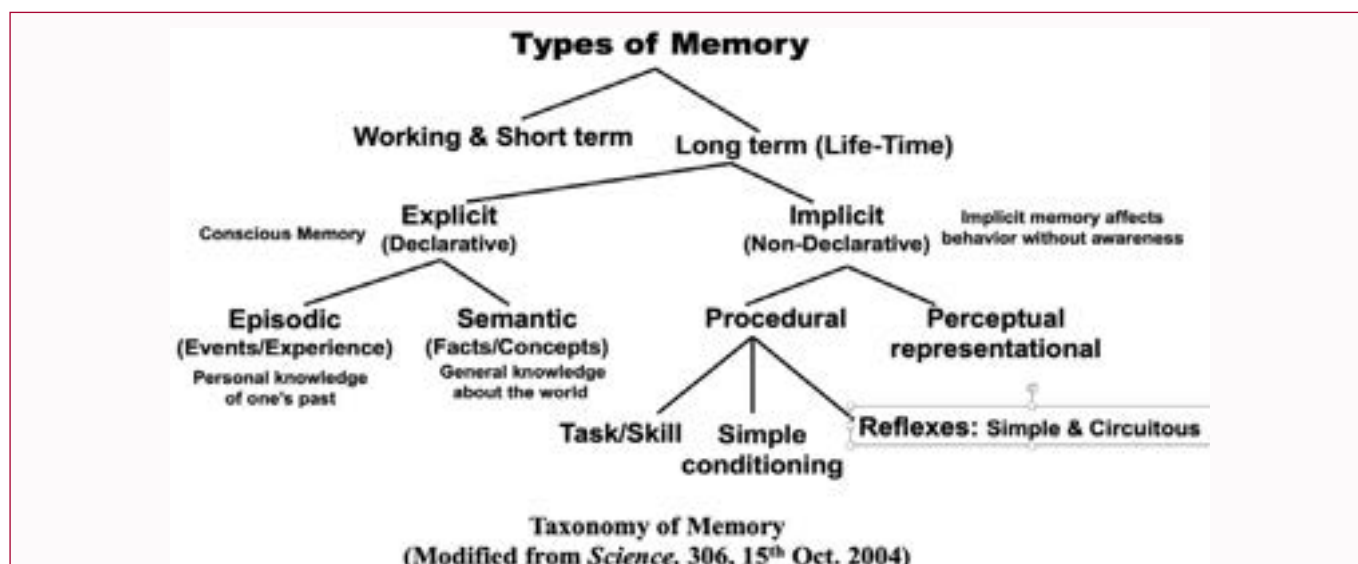

**Figure 4:** Different categories of memory as described in the text have been shown in the figure (modified from the journal *Science*, as referenced).

## Encoding and Algorithm

At present as we deal with encoding of only signal/data, this is based on binary arithmetic. However, as we deal with other information states, such as non-digitized information related to perception, non-digitized and non-factorizable information related to concept formation, information manifold related to theorization, and crystallized information related to wisdom or worldview formation, we are to take help of the disciplines respectively of geometry, symmetry, supersymmetry and finally the mathematics of a point (Figure 3).

## Memory Redefined

After redefining various information states and the mathematics required for their coding and algorithm formation, we can redefine what memory is.

The entire phenomenon of acquisition and storing data, information and events, happenings and experience, and of recalling and retrieval of those is called memory. The important parts of the definition is active acquisition of data and other information states. This is not merely a programmed sequence of instructions, or storing them in dynamic manifolds, and later recalling the retrievable on time. The process of storage, recall, and retrieval might fail at any point, which when happens is called memory loss. In human situations this failure is called forgetfulness.

To emphasize, in absence of perception there is no memory formation. Human kids around two years of age are in the process of sphincter control, developing mind operation and perception, and are, therefore, in the process of formation of new memory. Before this, their movement and behavior are signal-driven and are based on working memory. From all such senses, the memory is always

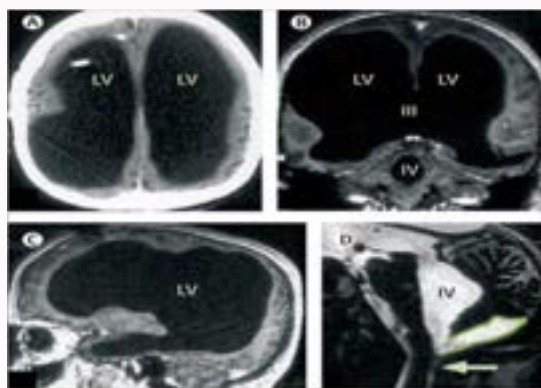

**Figure 5:** CT scan of the brain of a 44-year-old civil servant who has lost more than 90% of his brain tissue due to hydrocephalus, but lives almost a normal life with two children, having verbal IQ 84 and performance IQ 70 (Lancet. 2007;370(9583):262). The scan picture supports the view that for conscious activities, minimal neural structures required are the upper layers of the cerebral cortex and the brainstem.

biological, supported by “life”, and consciousness.

## Taxonomy of Memory

The taxonomy of memory is devised as observed in human situations in the context of a living brain. The taxonomy [4] is shown in Figure 4.

Signal memory, per se, is a misnomer. It does not happen. However, memory formation on signal activity is possible in presence of “life”. Cellular, intercellular, and subcellular signal memory, and pre-attentional signal memory is possible in live situations since the process is supported by life and consciousness. Pre-attentional memory is also called iconic (visual)/echoic (auditory) memory. It lasts for less than a second. In the memory test of Minimal Mental State Examination (MSME), if the patient can retrieve instantaneously the name of three items as told, his working memory, which lasts for a few seconds, is fine. If he can repeat those after 5 min to 15 min, the patient’s short-term memory is alright! Another example of short-term memory is remembering One-Time Password (OTP) for a few seconds or minutes. Long term memory formation requires neurotransmitter modulation at both presynaptic and postsynaptic levels, synaptic potentiation, and finally synaptic structural changes. This is helped by sound sleep, technically speaking of the resting state of the brain at zero-point energy state. A long-term memory could be coherently recalled in chronological order. Long term memory could be explicit or implicit. Explicit memory affects behavior with awareness. When the memory is of facts and concepts it is called semantic memory. When it is about happenings, events and experience, the memory is called episodic. Implicit memory affects behavior without awareness. This could be perceptual memory (perceptions stored in the subconscious) and procedural memory of task, skill, conditioned reflex etc. e.g., driving a car through reflex from eyes to the muscle of the legs with foot on accelerator, brake and clutch, Besides these major categories of memory, there are exceptional cases, such as photographic memory (was supposed to be present in Swami Vivekananda, Leonardo-da-Vinci, John von Neumann and many others), highly superior autobiographical memory which is a kind of the rarest and the strongest biological memory.

Two important parts of the brain are involved in storage of

memory namely, hippocampus for semantic memory, and amygdala for emotional memory [5].

## Emotion and Memory

There are effects of emotion on new memory formation. Emotion interferes with receptivity of inputs and execution of outputs in the memory process. When one is sad or angry, building up of memory is poor because of poor receptivity [6].

There is, however, a kind of emotional memory, which makes one re-live, re-experience the original perception in substance [7]. As examples, memory of an accident, terror attack, death of a near and dear, joy of the first kiss, joy of entering into one’s chosen profession etc. Characteristically emotional memory is robust, and it evokes similar emotional reactions as it did in the original situation. There are both neurological and psychological reasons for this. In emotional memory, there is simultaneous activation of amygdaloid nuclei and hippocampus. Psychologically, there is more involvement of “life” in such situations.

## Mechanism of Storage of Memory is not Clear!

Is memory storage a local event, distributed events, or a holographic phenomenon? Let us have a look at this.

### Is Memory Localized?

In the nervous system, hippocampus and amygdaloid nucleus are recognized to store memory [5]. We are not sure how much brain tissue is necessary for memory formation, storage and retrieval! There exists an extraordinary, and might be an exceptional, neurological case report [8] where the role of cerebral cortex and both hippocampus and amygdala in memory formation and storage has been put into doubt (Figure 5). We are not sure, whether the reported case is like an example of ‘white crow’!

### Memory could be in distributed Phase

Memory is distributed over biological systems and nature. Memory inside the brain is said to be distributed over synapses. In fact, human brain’s memory storage capacity is estimated on the basis of the number of synaptic nodes, on the assumption that one synapse stores about one byte of information. There are about 100 billion neurons, each making 1000 synapses. This results in 100 trillion data points, or about 100 terabytes of information. It is said that the human brain’s memory storage capacity could be nearly 2.5 petabytes (a million gigabytes). Calculation is on the basis of data storage capacity, assuming that the brain is a hardware, which the brain is not in reality! Also, most of the synapses in the organs like cerebral cortex and cerebellar cortex are tripartite, not merely neuro-neuronal but neuro-astrocyte-neuronal. One astrocyte makes synapses with thousands of neurons. Astrocytes, through a number of metabolic shuttles between neurons and itself, facilitates or inhibits memory formation. Within the biological system, beside the nervous system, every cell possesses its own and interactive memory. Some organs like the heart store memory. Memories stored in a transplanted heart have been found to create disturbing psychological situations occasionally in the recipient. DNAs store evolutionary memory. Epigenetic memory in histone proteins has been demonstrated both in animal and plant cells. The leaves of a touch-me-not plant do not react when it learns that the touch is not harmful! The example of cellular memory is vividly seen in memory B-, and T-lymphocytes of the immune system.

## Is Memory stored in a Holographic way?

The above simple view of memory storage in the neuronal synapse is contested by many neuroscientists since mechanistic formulations are not applicable in biological systems. The alternate view is that the brain stores memory holographically as evident from the fact that a good amount of memory still persists even after removal of hippocampus and amygdala. Also, a large amount of memory can be retrieved from a small piece of living brain tissue. The view says that the memory is stored in nature in classical holographic, quantum holographic [9,10], or information holographic ways [11].

## Memory in Artificial Device

Computer memory, RAM, is not true memory but denotes the data storage capacity and is measured in units of bytes; megabyte, terabyte etc. However, the cache memory of computers is an example of one of the fastest retrievals of instructional memory (?). Even some of the quantum particles have been said to have memory (?). "While AI models such as GPT from Open AI are trained on billions of pieces of data, they don't remember anything you show them or even anything they give back to you." ... "AI models are stateless. They have no memory." (Edo Liberty, founder and CEO of Pinecone, 20<sup>th</sup> March, 2023). Even the signal memory is not possible in artificial devices of intelligence since their signals are not supported by "life". For the same reasons, there is no process of acquisition, storage or retrieval of any memory whatsoever in brain dead patients!

## Memory in the Systems Universe and Systems Multiverse

There are similarities between the brain and the universe. About 75% of the brain weight is water, and so also of the universe. There are  $10^{11}$  neurons in the brain. There are  $10^{11}$  stars in a galaxy, and  $10^{11}$  galaxies, in turn, form the universe. There is reasonable agreement between connectivity amongst neurons and amongst galaxies. Two networks are believed to grow based on similar principles [12]. Approximately 70% of the universe is dark energy. So is also the brain's unaccountable economics of energy. The brain consumes 15% to 20% cardiac output having only 2% of body weight. In contrast to a desktop which draws 175 watts, and a laptop around 60 watts of power, our brain consumes only 20 to 30 watts of power but is able to perform mathematics or physics better than any human-made supercomputer! Nature as well as our brain is thus "green"!

How is it possible? In all likelihood the systems universe we live in, has a fabric of "life" in whatever way "life" may mean to scientists or otherwise, as life-form in a 4-D world or otherwise, as subtle, intangible, *prana*. Because of these interwoven fabrics of 'life', the systems universe can engage in homeostasis of uncertainty-certainty, symmetry breaking-symmetry making, and in economics of dark energy and visible energy. Since the universe has life, it has in all probability memory too. In the systems multiverse, on the other hand, the possibility of differentiation of Nascent nature/Mother Nature as subtle life is beyond our intellect's comprehension at present. Therefore, we will keep quiet on this issue.

## Memory: Science and Spirituality

All live-systems have their own memory. If a mechanistic system has any memory, whatsoever, it will be destroyed at the level of Zero-Point Energy (ZPE) level. Since the mind of a biological system continues to work beyond ZPE, semantic memory with the mind will continue to be there beyond ZPE, and in the cosmic scale this memory will be observable till the intergalactic space where differentiated

functions of mind undergo dissolution! It is expected that memory of mind will be incapacitated at this phase. Episodic memory, that is retained with "self", and emotional memory retained with "life" are supposed to be incapacitated at the boundary of the universe. Most of the interesting features happen almost always at the boundary of any system. With the origin of several universe(s), from the primordial unity, there is origin of the duality. From the *Essence of the Multiversity* differentiate the "self", the "life", and the mind respectively as the sentient entity, homeostatic entity and event-making entity at the border of the universe for operating within the systems universe. Expressing more lucidly, the nascent nature of the multiverse differentiates at the border of the universe into "life" as cognizable homeostatic unity, and consciousness in the multiverse differentiate into "self" to operate as the chief executive officer of the system universe. The mind generated operates as a communicator between any two conscious systems. The boundary of the system universe is the birth place and graveyard of any information-state. Within the *Essence of the Multiversity*, at the level of absolute unconditionality of both consciousness and nature, memory of any system, whatsoever, is not expected to be active.

## Spiritual Implications

Therefore, when we practice breathing into this *Essence* and breathing out this *Essence*, our evolutionary conserved memory, especially that of sexuality, gets cleansed. The *Essence* of the Multiversity thus operates as a "brain-washing machine" which is thought to be an important requirement for spiritual transformation of the being. In this science of Divinity, the contextual neuroscience is immersive neuroscience. Such a breathing practice in spirituality also revives the original memory of being with the Source.

## The Purpose of having Memory

Why is this phenomenon of memory? What is its purpose? We may say that the memories fundamentally add time dynamics in life, help in reflecting on the past as the past. It also offers the possibility of reusing all past experiences for the present. Thus, memory helps to ensure continuity between the past, present and the future. The time dynamics of facts, events, happenings in life are categorized in the form of memory. When Time-dynamics is dissolved in life, the human system becomes either a sage or an insane. Memory thus develops an identity of the entity. Memory defines what the entity is! Memories make each one of us unique [13]. Further, we all could think on the basis of our memory. Memory is essential for learning. Learning from the signal-driven sensations and learning from the information-driven perceptions are distantly different. Sensation-based learning could at best be called training. Only when supported by "life", a signal-based training can create working and short-term memory. Perception-based learning always creates memory. Building up memory is a part of education! Without memory there is little learning or any education! Intelligence-as-such, on the other hand, is difficult to observe in an artificial device. What is seen is the intelligence of the programmer in the program running the device. Intelligence is obviously biological and is also natural. Artificial Intelligence (AI), in this sense, is correctly called a "marketing term" by Federal Trade Commission, USA, 2023. Like artificial intelligence, machine learning is also a profitable marketing terminology. For intelligent decision-making, memory is essential. Memory offers intelligence, the handle of power. Finally, memory helps one to go back to the origin/the source, which has a vast spiritual significance. If evolution is looked at as the process of error/mistake corrections, spiritual transformation

of the being could be said as a gradual process of gaining back the original memory of the unity with the Source! Spiritually speaking, the best use of the power of memory is to use and reuse this original memory of unity with the Source!

## Conclusions and Perspectives

Every step of formation, storage, recall and retrieval of memory is mysterious. This paper ponders on such mysteries and also shows some ways to reach a solution for this. The paper concludes with the statement that the mystery of memory is intertwined with the mystery of "life". Where there is no "life", there is no memory. No lifeless system can acquire, store, recall and retrieve memory. This paper finally evokes the basic question, "what is life?"

The emerging perspective from this paper is the role of biotechnology in the future of AI. Our earlier paper [14] throws adequate light on this issue. With real memory, can we make artificial devices of intelligence more biological and thus more green? The business of AI, at its present state, is big but less innovative, more concentrated and less competitive. The endeavor thrives spending more on political lobbying for creating regulatory bodies and safety boards, and performs less in helping innovation in a biological way. The enterprise disrupts humanity more by creating humanoids, encouraging human being to unlearn what they have already learnt, especially the precise art of cognitive thinking. The present AI enterprises promote humanity less by promoting machine learning, and avoiding humanizing the technology. The present paper is expected to reverse the tide.

## Acknowledgement

This paper has been developed on the basis of the Author's presentation in the Summer School, 2023, for the students and faculty of IITs, on 7<sup>th</sup> of July, organized at Nabadwip, West Bengal, by Bhakti Vedanta Institute, Kolkata. The author is deeply indebted to the organizer.

## References

1. Mukhopadhyay AK. Science of Information. *Glob J Sci Front Res Phys Space Sci.* 2021;21(1):15-30.

2. Mukhopadhyay AK, Mukhopadhyay AS. Visualizing information as a dynamic entity roadmap of deep science, AI and humanity. *Psychol Behav Sci Int J.* 2019;13(4):555867.

3. Mukhopadhyay AK. The ladder of cognition: Abstract operation, molecular biology, systems science. *Ann Psychiatry Ment Health.* 2017;5(4):1107.

4. Miyashita Y. Cognitive memory: Cellular and network machineries and their top-down control. *Science.* 2004;306(5695):435-40.

5. Squire LR. The legacy of patient H.M. for neuroscience. *Neuron.* 2009;61(1):6-9.

6. Levine L, Burgess SL. Beyond general arousal: Effects of specific emotions on memory. *Social Cognition.* 1997;15(3).

7. Stanislavski L. Affective memory.

8. Feuillet L, Dufour H, Pelletier J. Brain of a white-collar worker. *Lancet.* 2007;370(9583):262.

9. Pribram K. Holonomic brain theory. 2020.

10. Joye SR. The Pribram-Bohm holoflux theory of consciousness: An integral interpretation of the Theories of Karl Pribram, David Bohm, and Pierre Teilhard de Chardin, 2016, California Institute of Integral Studies.

11. Mukhopadhyay AK. Information holograph. The structure, the source and its operation. *Int J Bioeng Neurosci Technol.* 2012;2(2):12-32.

12. Vazza F, Felletti A. The Quantitative comparison between the neuronal network and the cosmic web. *Front Phys.* 2020;8.

13. Miller G. Why are you and your brain unique? *Science.* 2012;338:35-6.

14. Mukhopadhyay AK, Kumar V, Singh A, Ranjan M, Mukhopadhyay T, Kumar A, et al. Future of AI: The cell shows the way. *Austin J Clin Pathol.* 2023;10(1):1079.